

## Order Example (주문예)

# HSR 0260

HSR 0260 33R B28 D:1 962L 3SETS  
 Type Radius Width Divider Length Q'ty

※ Option : HST-PAD 적용시 규격 끝에 HST-PAD 문구 추가 삽입

- Pitch (mm) : 26
- Bending Radius (mm) : 33, 50, 75, 100
- 가능내폭 (mm) B : 20~100 (+8mm) (표준 : 20, 28, 36, 44, 52, 60, 68, 76, 84, 92, 100)
- 내측높이 (mm) : 19
- 전체외폭 (mm) : B+12
- End Bracket 외폭 (mm) : B+14
- 전체높이 (mm) :  $H = 2R + 26$  (MIN)
- Free Span(m) : 1
- End Bracket 취부높이 (mm) : **H + 곡률반경의 25% Up**

### Chain

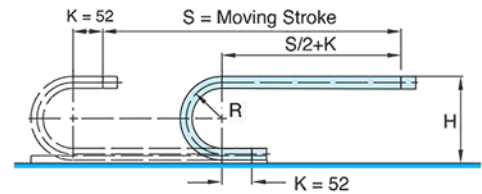
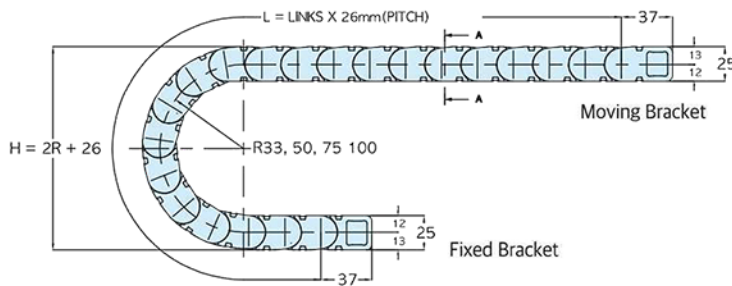

· Length  $L = \frac{S}{2} + \pi R + 104$

· Radius	R	33	50	75	100
· Height	H	92	126	176	226
	권장 취부높이	105	140	197	253

### B(Width)

※ 디바이더, 가로 분리대는 옵션입니다.

※ 영압부와 협의바랍니다.

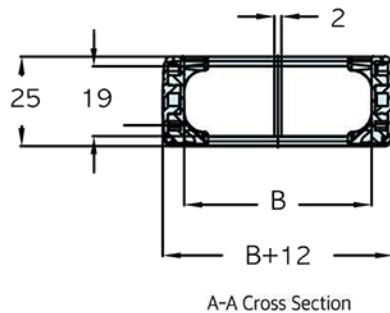

B	B+12	B	B+12
20	30	68	78
28	38	76	86
36	46	84	94
44	54	92	102
52	62	100	110
60	70		

### Brackets

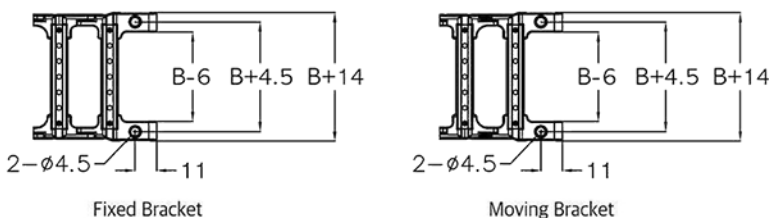

※ SL-015 타입과 End Bracket 부착 홈, 간격 동일

### Strain Relief(Eng.P)Option

