



## Order Example (주문예)

HSR 0380 45R B36 D:1 1406L 3SETS  
 Type Radius Width Divider Length Q'ty

# HSR 0380

※ Option : HST-PAD 적용시 규격 끝에 HST-PAD 문구 추가 삽입

- Pitch (mm) : 38
- Bending Radius (mm) : 45, 60, 75, 100
- 가능내폭 (mm) B : 36~140 (+8mm) (표준 : 36, 44, 52, 60, 68, 76, 84, 92, 100, 108, 116, 124, 132, 140)
- 내측높이 (mm) : 28
- 전체외폭 (mm) : B+16
- End Bracket 외폭 (mm) : B+20
- 전체높이 (mm) :  $H = 2R + 38$  (MIN)
- Free Span(m) : 1.5
- End Bracket 취부높이 (mm) : **H + 곡률반경의 25% Up**

### Chain

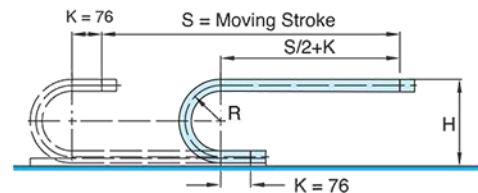
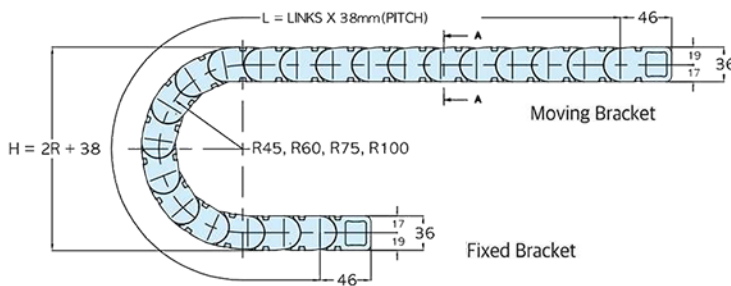

· Length  $L = \frac{S}{2} + \pi R + 152$

· Radius	R	45	60	75	100
· Height	H	128	158	188	238
	권장 취부높이	143	175	210	265

### B(Width)

※ 디바이더, 가로 분리대는 옵션입니다.

※ 가로 분리대 추가시 디바이더 2개 필수

※ 영업부와 협의바랍니다.

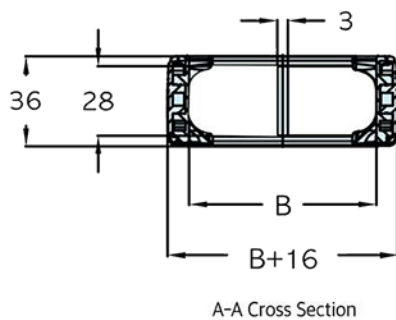

B	B+16	B	B+16
36	52	92	108
44	60	100	116
52	68	108	124
60	76	116	132
68	84	124	140
76	92	132	148
84	100	140	156

### Brackets

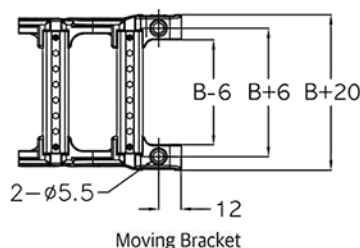
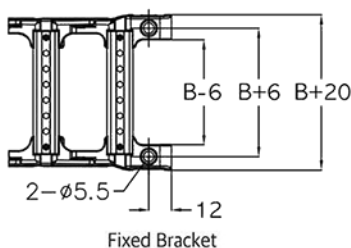

### Strain Relief(Eng.P) Option

